

# ISTRUZIONI DI MONTAGGIO ASSEMBLY INSTRUCTIONS

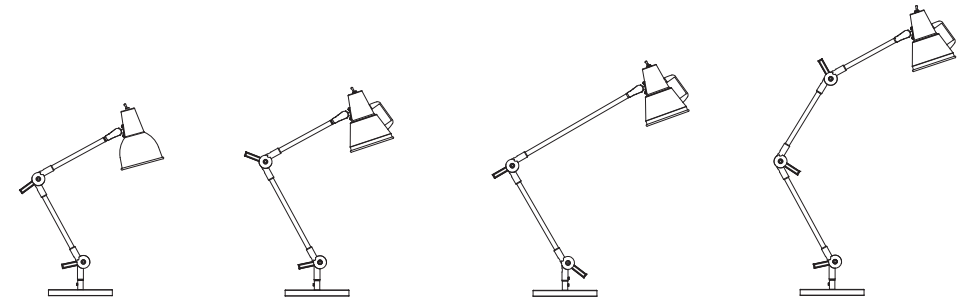

2010

2027

2029

2030

**IN CASO DI MONTAGGIO A CURA  
DELL'INSTALLATORE  
ATTENERSI ALLE INDICAZIONI**

**IN CASE OF INSTALLATION BY THE INSTALLER  
FOLLOW THE INSTRUCTIONS**

**DANS LE CAS D'UNE INSTALLATION PAR  
L'INSTALLATEUR  
SUIVRE LES INSTRUCTIONS**

**IM FALLE DER INSTALLATION DURCH DEN  
INSTALLATEUR  
FOLGEN SIE DEN ANWEISUNGEN**

**ATTENZIONE!  
LA GARANZIA E LA SICUREZZA DEL PRODOTTO È  
GARANTITA SOLO DAL RISPETTO DELLE PRESENTI  
ISTRUZIONI.  
L'AZIENDA NON RISPONDE DELL'USO  
IMPROPRIO DEL PRODOTTO**

**WARNING!  
THE WARRANTY AND SAFETY OF THE PRODUCT  
IS GUARANTEED ONLY BY COMPLIANCE WITH  
THESE INSTRUCTIONS.  
THE COMPANY SHALL NOT BE LIABLE FOR  
IMPROPER USE OF THE PRODUCT**

**ATTENTION !  
LA GARANTIE ET LA SÉCURITÉ DU PRODUIT NE  
SONT ASSURÉES QUE SI CES INSTRUCTIONS  
SONT SUIVIES.  
L'ENTREPRISE N'EST PAS RESPONSABLE DE  
L'UTILISATION INCORRECTE DU PRODUIT**

**WARNING!  
DIE GARANTIE UND SICHERHEIT DES PRODUKTS  
IST NUR GEWÄHRLEISTET, WENN DIESE  
ANWEISUNGEN BEFOLGT WERDEN.  
DAS UNTERNEHMEN HAFTET NICHT FÜR  
EINE UNSACHGEMÄSSE VERWENDUNG DES  
PRODUKTS.**

**morsetto  
da banco**  
clamp bench



- 1) inserire il perno e mettere in sicurezza la lampada
- 2) avvitare tramite un cacciavite

- 1) insert the pin and secure the lamp
- 2) screw in using a screwdriver

- 1) insérer la goupille et fixer la lampe
- 2) visser à l'aide d'un tournevis

- 1) den Stift einsetzen und die Lampe sichern
- 2) mit einem Schraubenzieher einschrauben

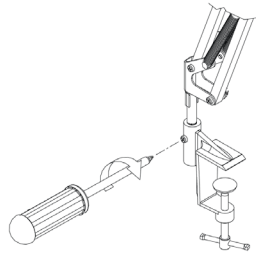

**base da tavolo**  
table base



- 1) inserire la base e mettere in sicurezza la lampada
- 2) avvitare tramite un cacciavite

- 1) insert the base and secure the lamp
- 2) screw in using a screwdriver

- 1) insérer la base et fixer la lampe
- 2) visser à l'aide d'un tournevis

- 1) den Sockel einsetzen und die Lampe befestigen
- 2) mit einem Schraubendreher einschrauben

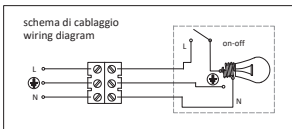
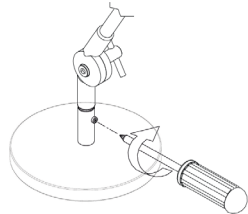

**ta = 35° C max**

**fissaggio verticale**  
vertical fixing

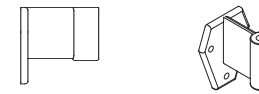

- 1) inserire il perno e mettere in sicurezza la lampada
- 2) avvitare tramite un cacciavite

- 1) insert the pin and secure the lamp
- 2) screw in using a screwdriver

- 1) insérer la goupille et fixer la lampe
- 2) visser à l'aide d'un tournevis

- 1) den Stift einsetzen und die Lampe sichern
- 2) mit einem Schraubenzieher einschrauben

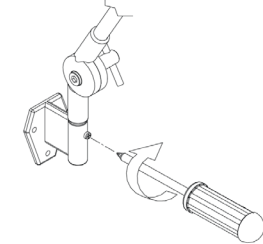

**fissaggio orizzontale**  
horizontal fixing



**DETTAGLI**  
DETAILS

**regolazione inclinazione  
cappello massima +/- 45°**

**maximum cap tilt  
adjustment +/- 45°**

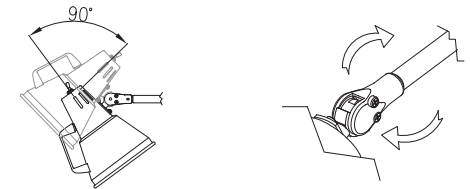

**regolazione snodo  
minimo 30°/massimo 220°**

**joint adjustment  
minimum 30°/maximum 220°**

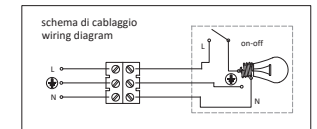
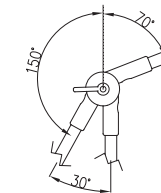

**ta = 35° C max**